

NEW WATER-COOLED TYPE SCREW CHILLERS



HITACHI

Hitachi Appliances, Inc.

URL : <http://www.hitachi-ap.com>

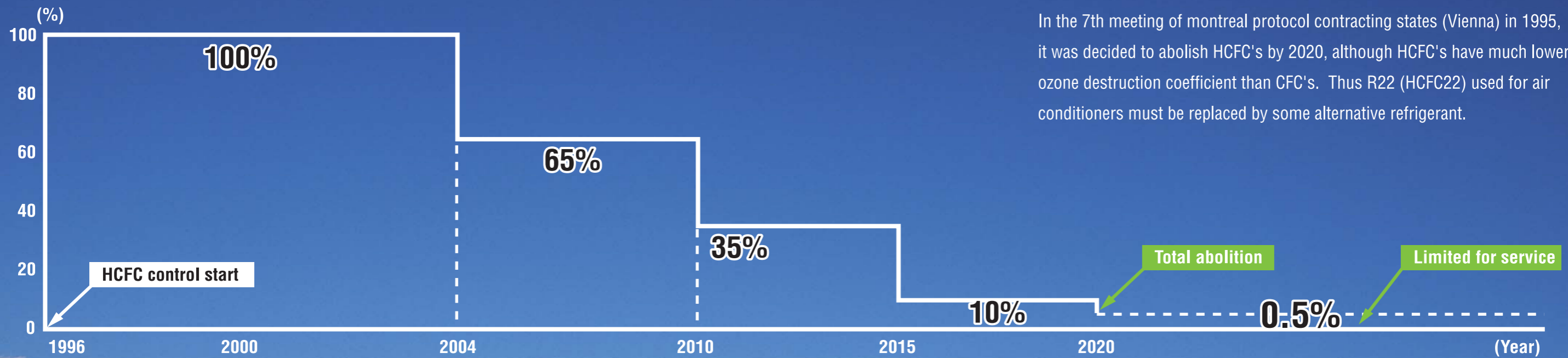
Specifications in this catalogue are subject to change without notice in order that HITACHI may bring the latest innovations to their customers.

Distributed By :



R410A

Designed to reduce the impact on the environment compared to HCFC,CFC



In the 7th meeting of montreal protocol contracting states (Vienna) in 1995, it was decided to abolish HCFC's by 2020, although HCFC's have much lower ozone destruction coefficient than CFC's. Thus R22 (HCFC22) used for air conditioners must be replaced by some alternative refrigerant.

Why does Hitachi use R410A?

Refrigerant (Refrigerant Type)	R22 (HCFC)	R134a (HFC)	R410A (HFC)
ODP (Ozone Depletion Potential)	0.055	0	0
GWP (Global Warming Potential)	1,700	1,300	2,000
Cooling Capacity	100%	62%	140%
Amount of refrigerant	100%	161%	71%
GWP x Amount of refrigerant	1,700	2,093	1,420

Hitachi is the world first to successfully introduce R410A refrigerant in all its range of products, starting from room air-conditioners, package air-conditioner and presently; SCREW CHILLER. Innovative technology is applied for the design and development of the compressor, refrigerant cycle, chiller itself, etc. Accordingly, the Hitachi R410A screw chiller achieves high COP while accommodating the operating pressure of R410A, which is 39% higher than that of R22.

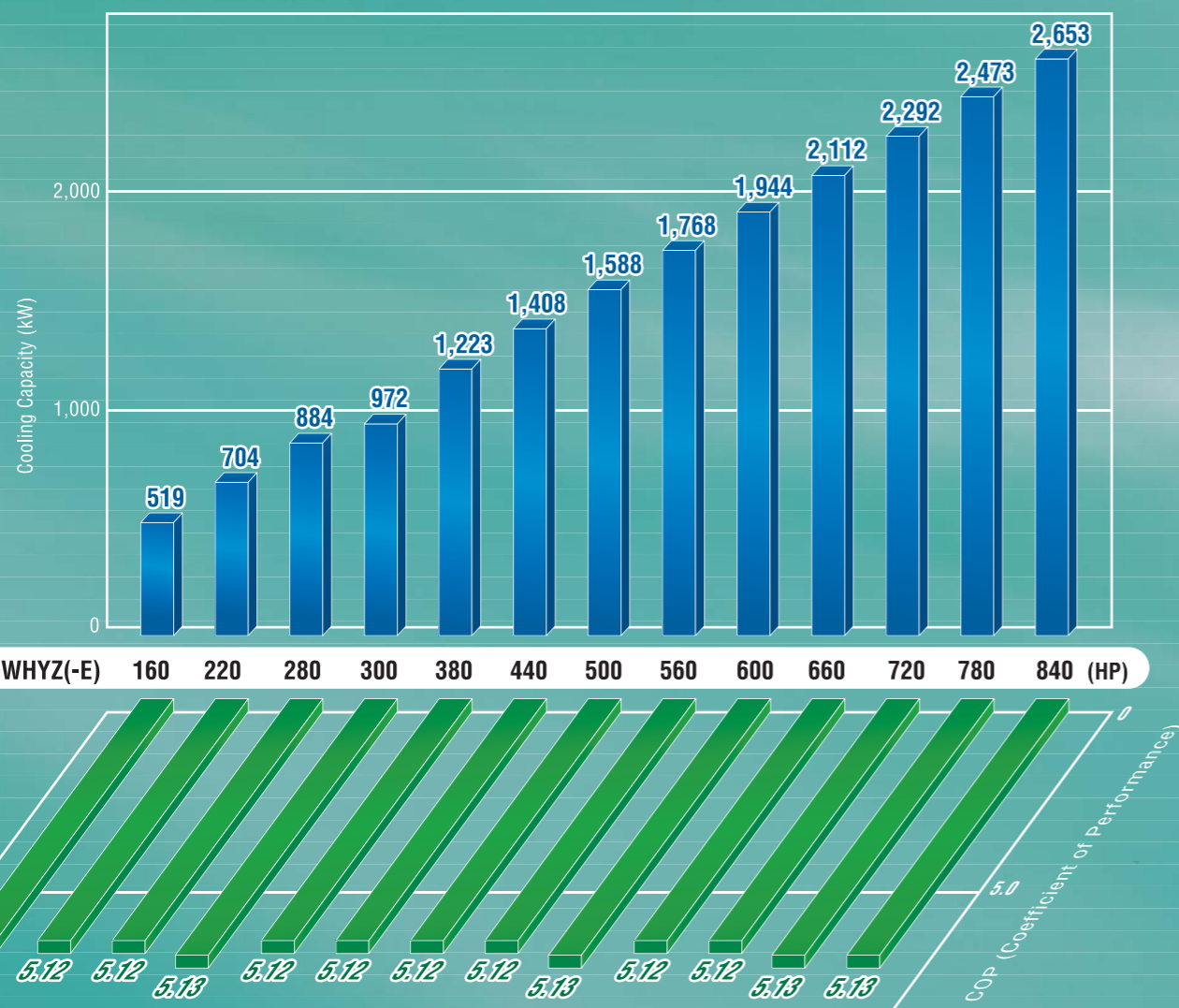
In terms of GWP (Global Warming Potential), R410A is not more environmentally considerate than other refrigerants. However, since the quantity of refrigerant required for equivalent cooling capacity is smaller (see the table), R410A has less impact on the environment than other refrigerants.

COP > 5.1

(0.7kW/RT)

COP of more than 5.1 in all models!

By using R410A refrigerant and optimizing the design of equipment for R410A (compressor, heat exchanger, refrigerant cycle, etc.), the COP value is dramatically improved to more than 5.1 for all models.



Product Features of HITACHI SCREW CHILLERS

Hitachi's water chiller, with its high efficiency and various functions, can meet a wide range of needs, not only in the field of air conditioning control for commercial use but also in strict temperature control for production processes.



Product Features

- Compact and Light Weight
- Modular System
- Excellent Control Functions

Unique Technology for High Performance and Reliability

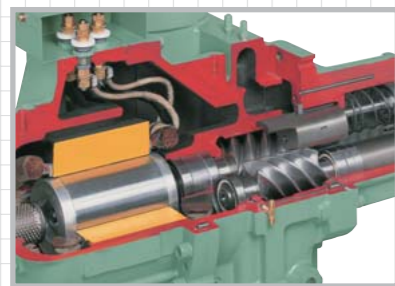
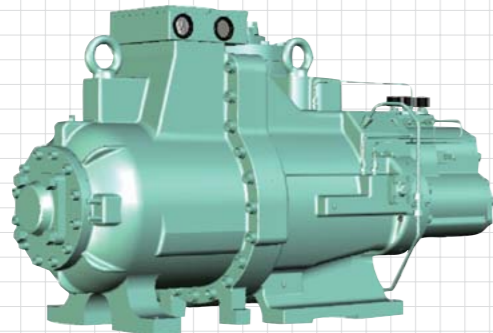
- High-performance A type Screw Compressor
- Precise Capacity Control Technology
- Highly Reliable Shell & Tube Heat Exchanger
- Safety Devices Equipped as Standard

Unique Technology for High Performance and Reliability

High-performance A-type Screw Compressor

Built-in Cyclone Oil Separator

Low oil carrying-out is realized, therefore heat transfer efficiency is maximized.

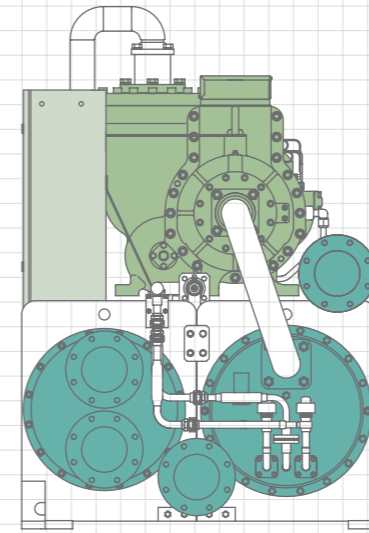
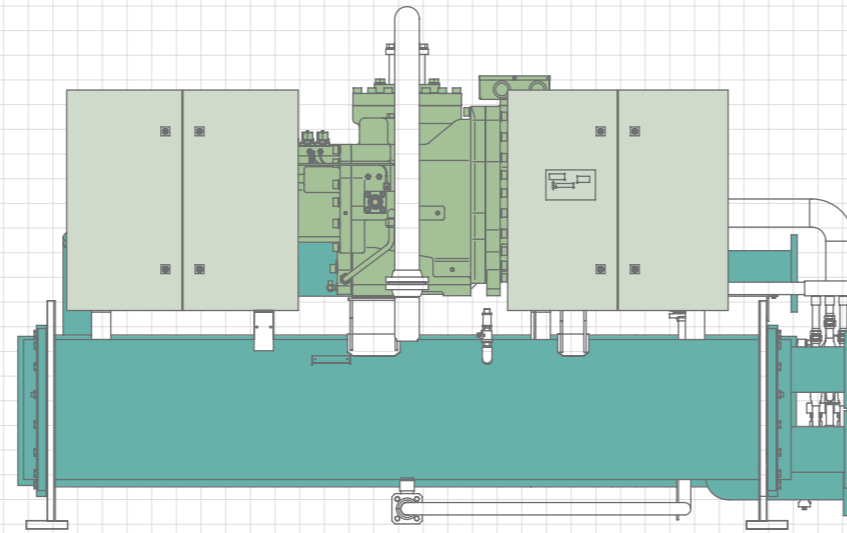
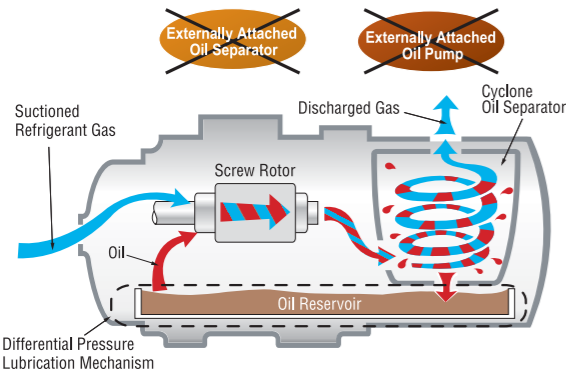


* The product photograph is a conceptual image, and may differ from the actual product.

No outside pump is required due to the reliable differential-pressure oil-feeding system.

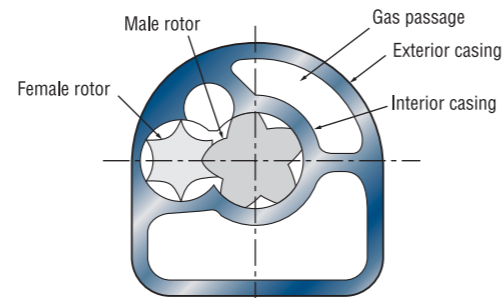
This oil-feeding system does not use any electrical mechanism, prevents the compressor from being damaged and maintains long-term stable operation.

Operation Image



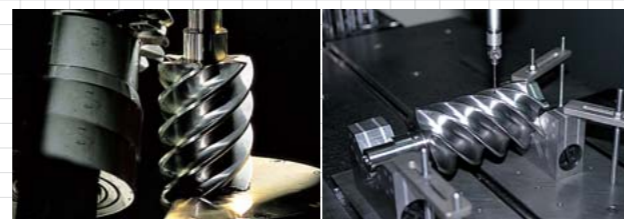
Low Vibration, Low Noise

Without the conventional demister chamber system, no noise is produced during oil separation of discharge gas. A vibration-proof base is not required for the chiller body thanks to the firmly-secured, low-vibration screw compressor made by HITACHI.



High Technology by Internal Manufacture

Because all manufacturing processes, from rotor manufacturing to unit assembly, are done internally, exceptional reliability is achieved.

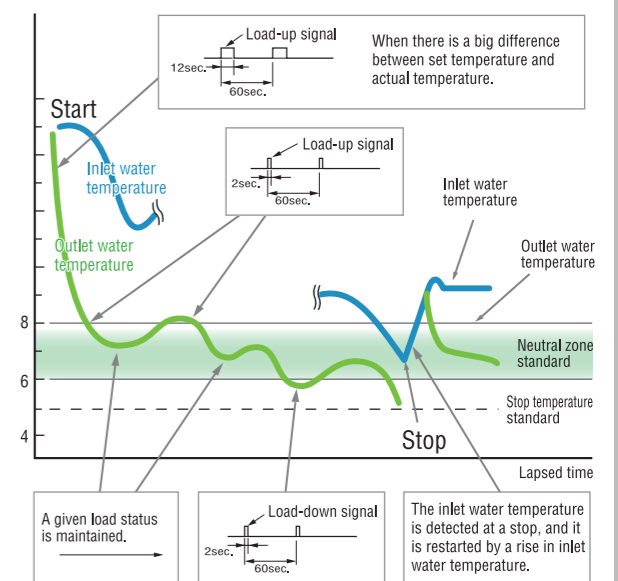


Precise Capacity Control Technology

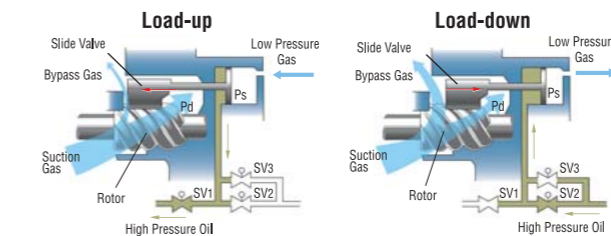
Continuous Capacity Control

The temperature of the chilled water outlet can be kept at the set temperature $\pm 1^\circ\text{C}$ by continuous capacity control, so it is suitable for industrial use.

Continuous Capacity Control Image



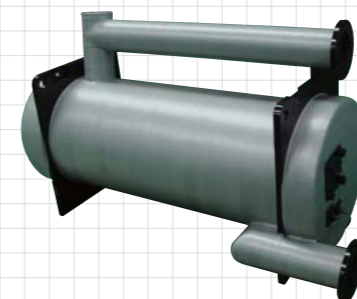
Capacity Controller Structural Outline HITACHI Patented System



Pd: Discharge pressure, Ps: Suction pressure, SV1,2,3: Solenoid valve : Valve open : Valve close

Highly Reliable Shell and Tube Heat Exchanger

- Simple structure and easy for maintenance
- Reduced cost and adapted to satisfy various demands
- Freeze protection thermostat
- Integral and reliable performance



Safety Devices Equipped as Standard

The Hitachi chiller is equipped with several safety devices as standard. Those safety devices protect the unit from abnormal operation for higher reliability and longer lifespan of the chiller.

List of Safety Devices

- Three-Phase Over-current Relay
- High-Pressure Switch
- Low-Pressure Switch
- Oil Heater
- Internal Thermostat for Compressor Motor
- Fusible Plug
- Freeze Protection Thermostat
- Reverse Phase Protection Relay
- Discharge Gas Thermostat
- Operation Hour-Meter and Safety Valve

Product Features

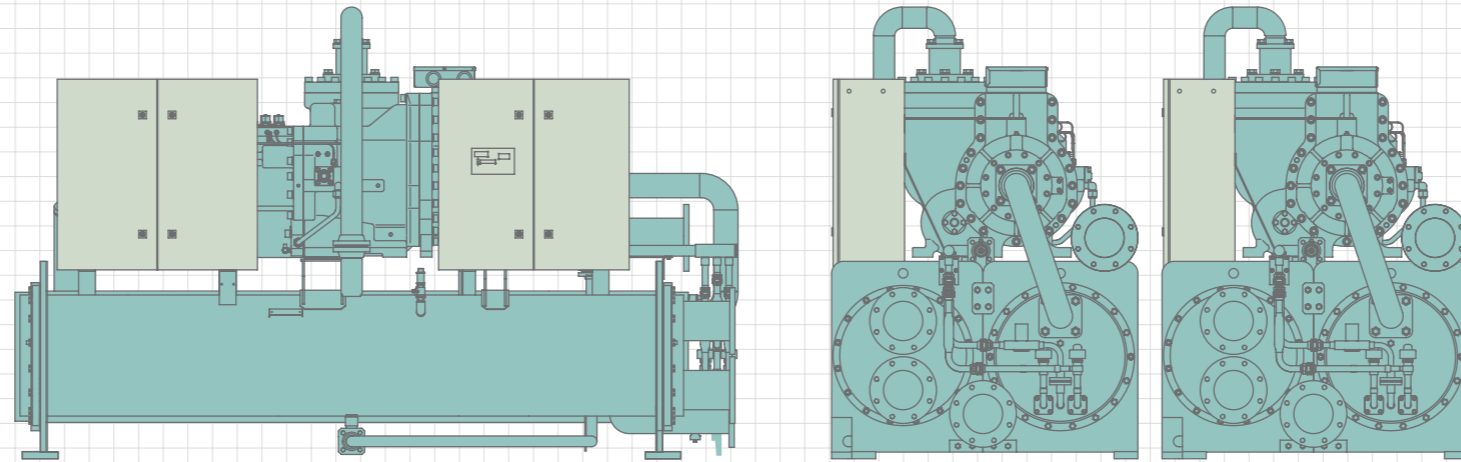
Compact and Light Weight

Comparison of net weight and installation space with R22 chiller unit (equivalent capacity)

	Net Weight (kg)		Ratio*
	R22 units	R410A units	
220 HP	5,204	3,507	67%
280 HP	5,420	3,850	71%
300 HP	5,638	3,895	69%

	Installation Footprint (m ²)		Ratio*
	R22 units	R410A units	
220 HP	5.04	3.88	77%
280 HP	5.04	3.88	77%
300 HP	5.04	3.88	77%

* Relative to R22 chiller unit (equivalent capacity) as 100%



Excellent Control Functions

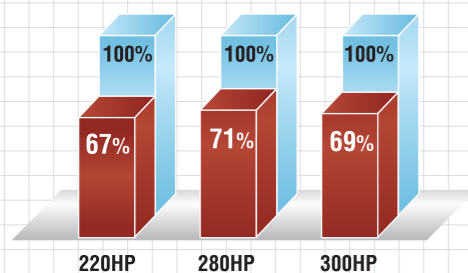
Liquid Crystal Screen Display (Optional Accessory)

- Big colorful liquid crystal display
- Man-machine conversation screen, display content completely.
- Show real time data
- Time starting function
- Leave message board (for shift)
- Communication adapter provides Communication with RS485 physics connection to BMS.

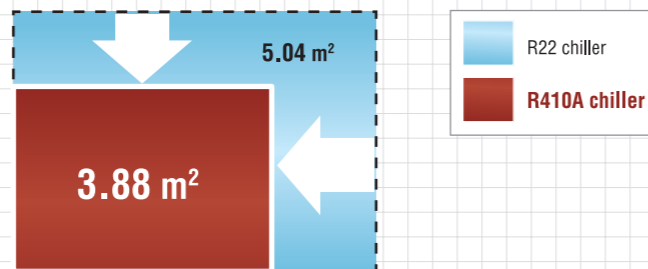


Image of Display

Net Weight Comparison (220-300HP)



Installation Footprint Comparison (220-300HP)



Modular System

These R410A units feature a modularization cycle structure, so each module can be packed and transported individually, for more convenient local installation and displacement. Furthermore, the refrigerant system of each module can be operated independently, which makes maintenance easier.

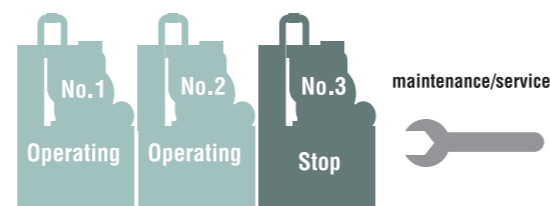
Current units (All-in-one type unit)

Operation must be completely stopped during maintenance and service.



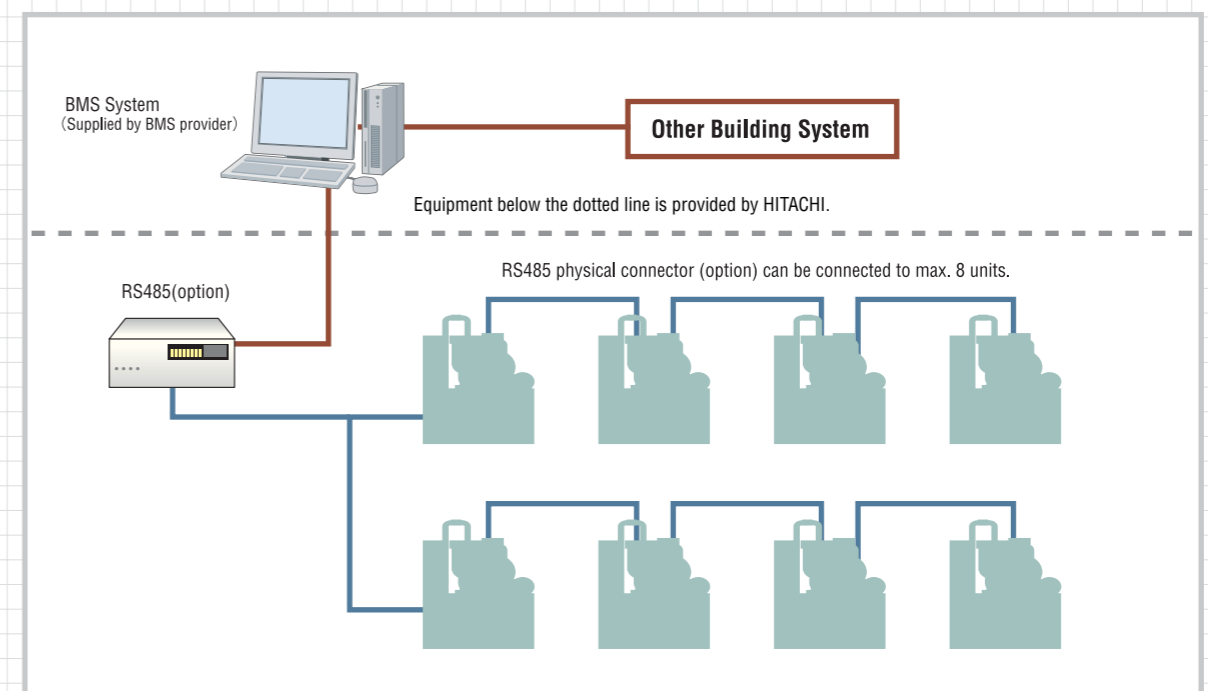
New R410A Chiller (3-module unit)

A complete stop is not necessary, because maintenance/service can be done independently for each module.



Building Management System (BMS)

The Hitachi chiller can be connected to the BMS system through an RS485 BOX as an option.



* : HITACHI will provide its own protocol for RS485 communication by using 2 wiring connections. Please contact your local HITACHI dealer for more details.

Specifications

Model: RCUA-WHYZ(-E) ^{*3)}	HP	160	220	280	300
Nominal Cooling Capacity ^{*1)}	kW	519	704	884	972
	USRT	147.6	200.2	251.4	276.4
	kcal/h	446,300	605,500	760,400	835,900
COP	-	5.12	5.12	5.12	5.13
Condenser Water Flow Rate	m ³ /h	107	145	182	200
Chilled Water Flow Rate	m ³ /h	89	121	152	167
Compressor	Quantity	1			
Condenser	-	Shell-and-Tube Type			
Water Cooler	-	Shell-and-Tube, Dry Expansion Type			
Outer Dimensions	D x W x H mm	3,018 x 1,285 x 1,900			
Shipping Dimensions	D x W x H mm	3,363 x 1,488 x 2,173			
	Number	1 Module			
Net Weight	kg	3,482	3,507	3,850	3,895
Shipping Weight	kg	3,878	3,903	4,246	4,291

Model: RCUA-WHYZ(-E) ^{*3)}	HP	380	440	500	560	600
Nominal Cooling Capacity ^{*1)}	kW	1,223	1,408	1,588	1,768	1,944
	USRT	347.8	400.0	451.6	502.8	553.0
	kcal/h	1,051,900	1,211,100	1,366,000	1,520,800	1,671,800
COP	-	5.12	5.12	5.12	5.12	5.13
Condenser Water Flow Rate	m ³ /h	145 / 107	145 / 145	182 / 145	182 / 182	200 / 200
Chilled Water Flow Rate	m ³ /h	121 / 89	121 / 121	152 / 121	152 / 152	167 / 167
Compressor	Quantity	2				
Condenser	-	Shell-and-Tube Type				
Water Cooler	-	Shell-and-Tube, Dry Expansion Type				
Outer Dimensions	D x W x H mm	3,018 x 2,670 x 1,900				
Shipping Dimensions ^{*2)}	D x W x H mm	3,363 x 1,488 x 2,173				
	Number	2 Modules				
Net Weight	kg	3,507 / 3,482	3,507 / 3,507	3,850 / 3,507	3,850 / 3,850	3,895 / 3,895
Shipping Weight	kg	3,903 / 3,878	3,903 / 3,903	4,246 / 3,903	4,246 / 4,246	4,291 / 4,291

Model: RCUA-WHYZ(-E) ^{*3)}	HP	660	720	780	840	
Nominal Cooling Capacity ^{*1)}	kW	2,112	2,292	2,473	2,653	
	USRT	600.6	651.8	703.0	754.2	
	kcal/h	1,816,600	1,971,500	2,126,400	2,281,300	
COP	-	5.12	5.12	5.13	5.13	
Condenser Water Flow Rate	m ³ /h	145 / 145 / 145	182 / 145 / 145	182 / 182 / 145	182 / 182 / 182	
Chilled Water Flow Rate	m ³ /h	121 / 121 / 121	152 / 121 / 121	152 / 152 / 121	152 / 152 / 152	
Compressor	Quantity	3				
Condenser	-	Shell-and-Tube Type				
Water Cooler	-	Shell-and-Tube, Dry Expansion Type				
Outer Dimensions	D x W x H mm	3,018 x 4,055 x 1,900				
Shipping Dimensions ^{*2)}	D x W x H mm	3,363 x 1,488 x 2,173				
	Number	3 Modules				
Net Weight	kg	3,507 / 3,507 / 3,507	3,850 / 3,507 / 3,507	3,850 / 3,850 / 3,507	3,850 / 3,850 / 3,850	
Shipping Weight	kg	3,903 / 3,903 / 3,903	4,246 / 3,903 / 3,903	4,246 / 4,246 / 3,903	4,246 / 4,246 / 4,246	

NOTES:

1. The nominal cooling capacities are based on the following conditions.

*1) Chilled Water Inlet / Outlet Temperature: 12°C / 7°C
Condenser Water Inlet / Outlet Temperature: 30°C / 35°C

2. Applicable Power Supplies

Main Power Source (3φ) 380V / 50Hz 415V / 50Hz
Control Power Supplies (1φ) 220V / 50Hz 240V / 50Hz

3. Working Range

Condenser Water Outlet Temperature: 22°C to 37°C
Chilled Water Outlet Temperature: 5°C to 20°C

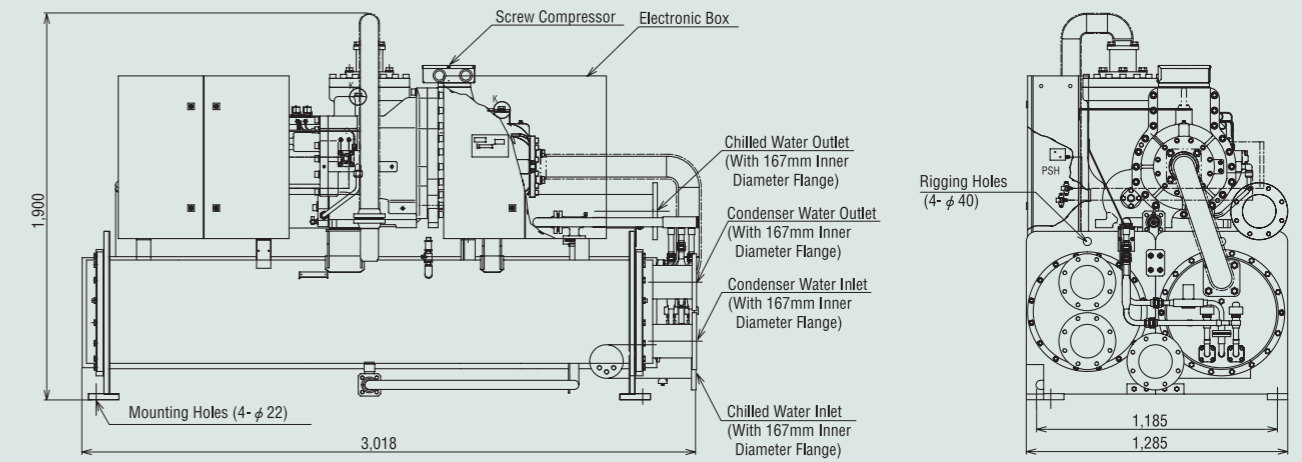
4. *2) The units greater than RCUA380WHYZ including RCUA380WHYZ consist of two modules or more than two and are separately shipped.

5. *3) RCUA-WHYZ-E is a model equipped with Liquid Crystal Screen Display (option).

Dimensions

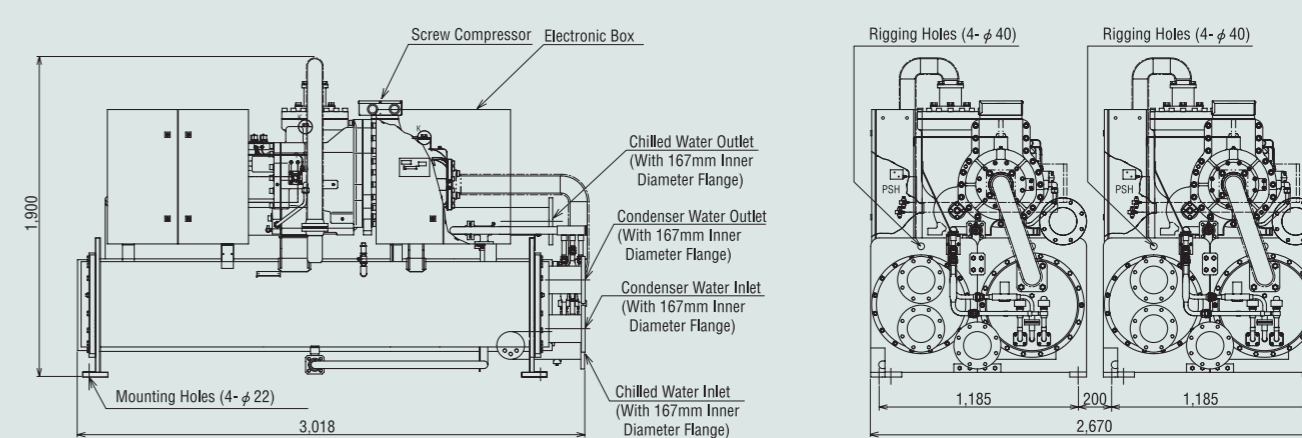
RCUA160, 220, 280 and 300WHYZ(-E)

(unit: mm)



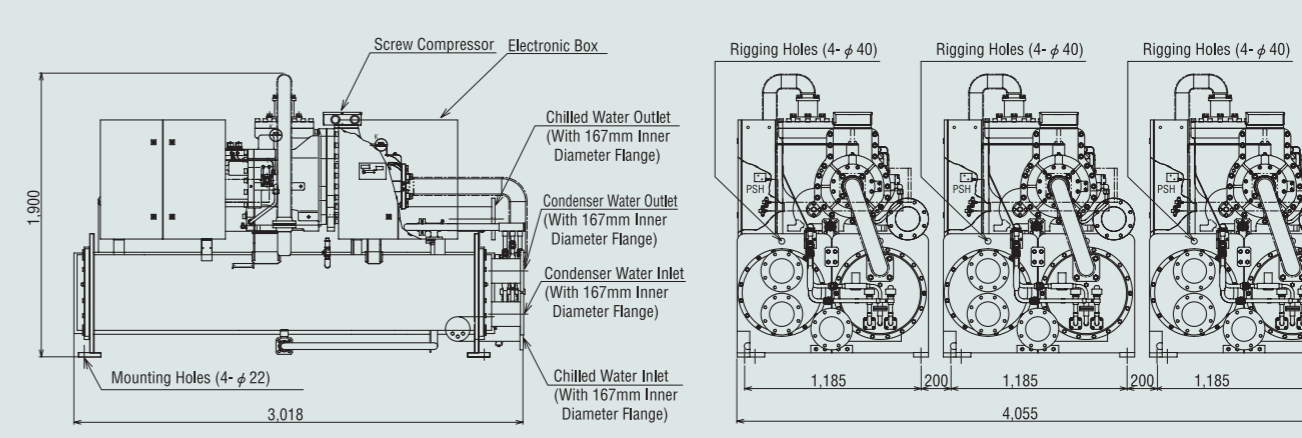
RCUA380, 440, 500, 560 and 600WHYZ(-E)

(unit: mm)



RCUA660, 720, 780 and 840WHYZ(-E)

(unit: mm)



6. The unit with liquid crystal display differs from the unit with segment code display in electric box, however, both have the same outer dimensions.

7. Communication adapter connecting the unit to BMS (Building Management System) is an optional accessory, please contact with HITACHI or HITACHI distributor if required.

Safety Devices Equipped as Standard

Three-Phase Over-current Relay, High-Pressure Switch, Low-Pressure Switch, Oil Heater, Internal Thermostat for Compressor Motor, Fusible Plug, Freeze Protection Thermostat, Reverse Phase Protection Relay, Discharge Gas Thermostat, Operation Hour-Meter and Safety Valve.