

**HITACHI**



# Centrifugal Chiller

**High Efficiency**

**GFG-S/SIT Series**

**GXG-S/SIT Series**

**GSG-S/SIT Series**



# CENTRIFUGAL CHILLER

## High Efficiency Centrifugal Chiller

- **HC-F-GFG-SSC Series** (Super High Efficiency Type)
  - **HC-F-GXG-S Series** (High Efficiency Type)
  - **HC-F-GSG-S Series** (Compact Type)
- 1,055~7,032kW (300~2,000USRT)**

\*Capacity can be extended up to max. 2,500USRT with single compressor.

## High Efficiency Inverter Controlled Centrifugal Chiller

- **HC-F-GFG-SITSC Series** (Super High Efficiency Type)
  - **HC-F-GXG-SIT Series** (High Efficiency Type)
  - **HC-F-GSG-SIT Series** (Compact Type)
- 1,055~4,747kW (300~1,350USRT)**

Hitachi High Efficiency Centrifugal Chillers realize world top-level high efficiency and downsizing thanks to the advanced technologies to optimize the design of compressors and heat-exchangers. Several series of product lineup and flexible model selection satisfy huge variety of customers' demand such as energy saving, space saving, etc. In addition, Hitachi's unique technologies accumulated through over 80-year history ensure long term stable operation.

## Advantages

### ■ Excellent Energy-Saving Effect

First class efficiency greatly contributes energy saving of users.

### ■ Compact Design

Significantly compact and light weight design enables space saving and easy replacement.

### ■ High Reliability

Hitachi's unique technologies enhance high reliability and long term stable operation.

Featuring Ozone-safe

**HFC134a**



# Global Warming Prevention

## Energy saving by high-efficiency centrifugal chillers

Global warming refers to the phenomenon of global rising in average atmospheric temperatures due to increased volume of CO<sub>2</sub> and methane as a result of burning fossil fuels such as petroleum and coal. The 1995 IPCC\* Report predicted that if the emission of CO<sub>2</sub>, etc. continued as it was, the atmospheric temperature would rise by as much as 2°C by the end of the 21st century and, as a result, the sea level would rise by approximately 50 cm from the present level. In such circumstances, it is even more important to save the energy consumed by air conditioners in order to cut CO<sub>2</sub> emission.

\* IPCC: Intergovernmental Panel on Climate Change

## Our Key Technologies Realizing High-Efficiency.

### High-efficiency Refrigerant Cycle

Increased refrigerating cycle efficiency

- 2 stages compression cycle with economizer

**Max. COP  
7.0  
Achieved**

### High-performance Heat Exchanger

Increased efficiency resulted from improved performance of heat exchanger

Employment of high-performance heat exchange tubes.  
Optimal structural design of heat exchanger to match the behavior of refrigerant.

### High-efficiency Compressor

Increased compressor efficiency

- 3 dimensional blade impeller (2 stages)
- Optimally designed diffuser with vane
- Low rotating speed compressor enables the use of low-loss bearing structure.
- Semi-hermetic design

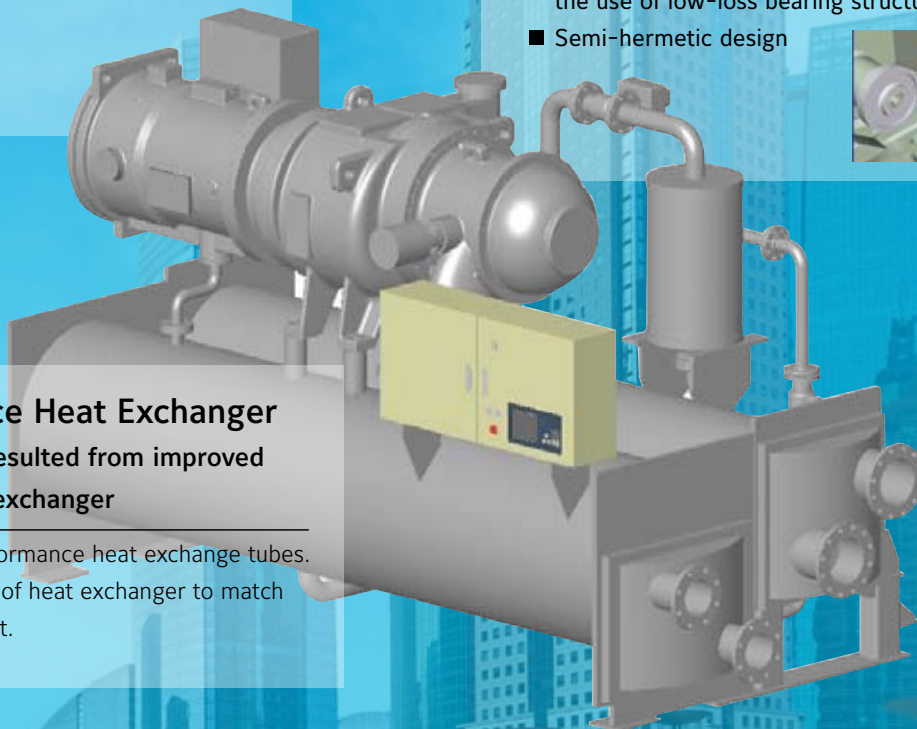

# Advantages



## Top-class Compact Design and Light Weight Design

- The compact design greatly improves flexibility in installation.
- Realizing space saving of machine room.
- Easy carry-in to machine room.
- Suitable for replacement of long-operating chillers.
- Significant reduction of refrigerant volume.

### • Comparison of Chiller Size (Comparison of 1000RT models)

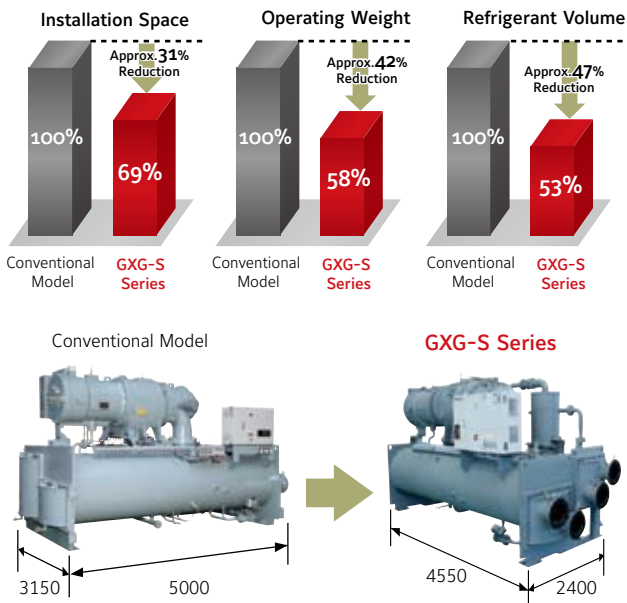

## New Type Economizer

Improvement of vapor-liquid separation performance and significant downsizing are realized by the use of Newly-developed economizer. (cyclonic system)

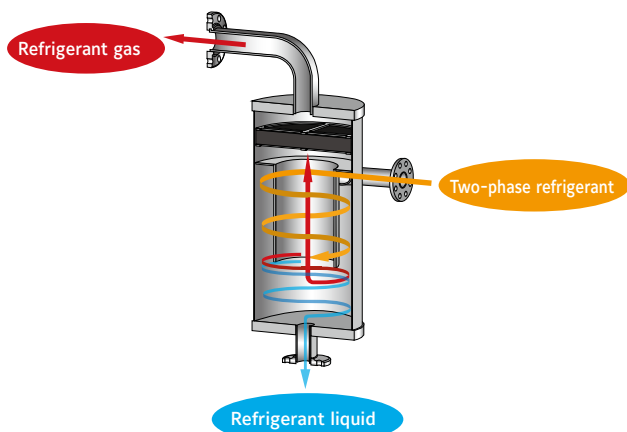

## Easy Operation with Touch Panel Type Control Panel

- 10.4 inch color touch panel screen
- Monitor various operating data
- Indicate trend graph during operation
- Trend data for max. 40 hours. (Updated every 1 hour)
- Indicate and store operation history for the past 12 hours (Updated every hour)
- Indicate and store failure and alarm history (latest 6 times each)
- Show Handling Guide in case of failure
- Automatic restart function after instantaneous power failure (Option)
- Multilingual Languages Indication (Japanese, English, Chinese [Simplified, Traditional], Portuguese)
- Download 3-month operation data to USB memory



Operation screen

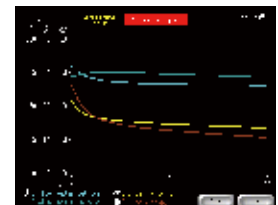

Failure screen



Trend data screen

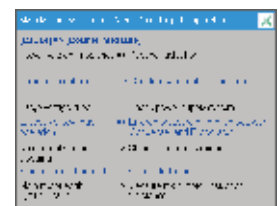

Handling guide screen

## Compatible with BMS

Chiller control panel is equipped with RS485 communication port and compatible with Building Management System through MODBUS RTU protocol.

## Quick automatic restart after power failure.

Chiller automatically starts up after instantaneous power failure (less than 10 sec.) and reverts to normal operation in shortest period.



## 2-stage Compression Cycle

To improve compressor efficiency, refrigerant economizer is added with 2-stage compressor equipped with 2 impellers, as shown in the drawing below. In this case, the refrigerant goes through two expansion devices. When the refrigerant goes through the first device, some of the refrigerant flashes, or become a gas.

The flashed refrigerant is introduced to the compressor between the two stages. In the one-stage compressor cycle without the economizer, all refrigerant flows in the cycle. Comparatively, in the 2-stage compressor cycle the part of the refrigerant is bypassed from the economizer to the 2-stage impeller.

### • 2-stage Centrifugal Chiller Cycle

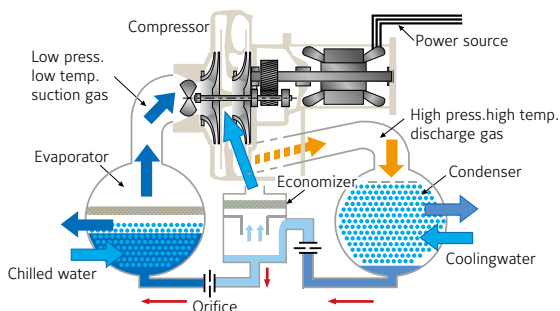

## High Reliability Lubrication System

Direct refrigerant cooling of lubrication oil in oil cooler without cooling water piping increases reliability.

### • Lubrication Oil Supplying System

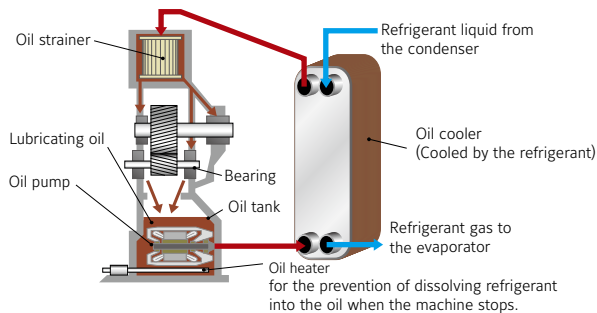

## Wider Operating Range

Stable operation continues even when rise of condenser pressure due to cooling water temperature in hot summer and/ or proceeding of tube fouling.

### • Example of rising cooling water temperature due to rising ambient temperature

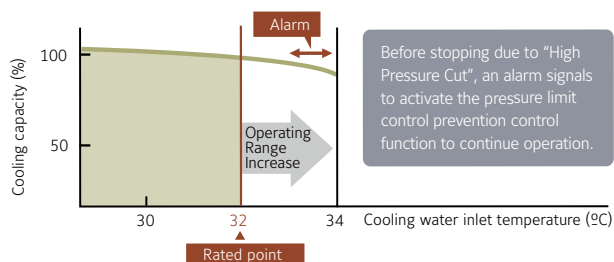

## Surge Protection

Adopting strict criteria specified in JIS for stable operation under high cooling water temperature. 3D 2-stage impeller enables stable operation even at low cooling load or high cooling water inlet temp. which prevents occurrence of surge.

### • Compressor characteristic comparison

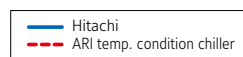
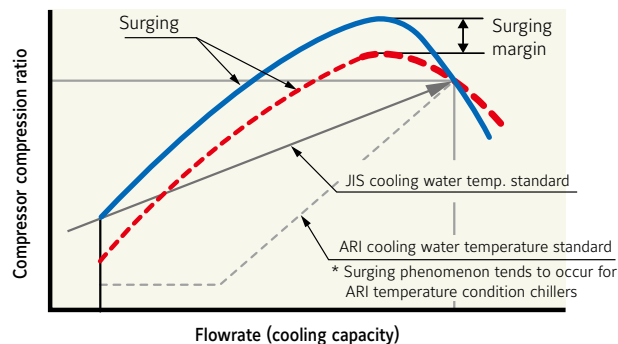

Load	JIS	ARI
100%	32°C	29.4°C
75%	30.75°C	23.9°C
50%	29.5°C	18.3°C
25%	28.25°C	18.3°C
0%	27°C	18.3°C

\* This figure shows general characteristics and does not provide any guarantees as to the performance.

## Other Unique Feature to Enhance Reliability

- Key-free impeller coupling system
- Accurate chilled water temperature control within  $\pm 0.2^\circ\text{C}$
- Low noise and longer bearing life due to lower rotation speed of 2-stage compression cycle.
- Continuous oil recovery with automatic refrigerant cleaner
- Prevention of oil degradation by removing residual water with filter dryer

## Operational Item & Function

- Min. cooling water temperature  $12^\circ\text{C}$  (GFG/GXG), and  $15^\circ\text{C}$  (GSG)
- Thermal insulation
- Spring isolator
- Max. working pressure up to 2.5Mpa
- Ball type automatic tube cleaning system for chilled & cooling water
- Chilled & cooling water variable flow control
- Marine type water box / Hinged type water box
- Min. cooling capacity 10% (with hot gas bypass)
- Large temperature difference (to reduce the water flow rate)
- Delivery in knockdown form  
(4 pieces-compressor, heat exchangers, economizer, control panel, 5 pieces-evaporator & condenser is also separated.)
- Soft starter (for low voltage)

# Advantages



## Hitachi High Efficiency Inverter Controlled Centrifugal Chiller

Hitachi High Efficiency Inverter-controlled Centrifugal Chillers realize energy-saving operation throughout the year utilizing variable motor speed control with inverter unit, drastically improving partial load efficiency under low cooling water temperature

condition in off-peak seasons. In addition, the chillers have many unique energy saving functions which satisfy the demand to minimize the energy consumption.

Excellent Efficiency throughout the Year



High Efficiency Heat Exchangers

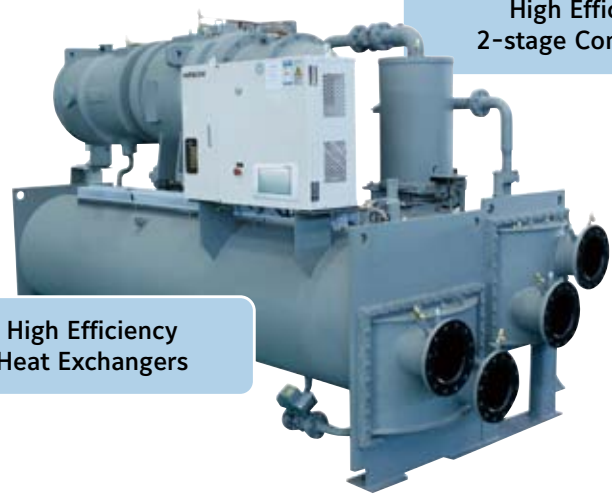

High Efficiency 2-stage Compressor

Max. Partial Load  
COP **22.4**  
IPLV **11.5**

\*GFG-SITSC model

## COP during winter season is improved to maximum 330%.

GFG-SIT/GXG-SIT/GSG-SIT Series can be operated stably even in the very low cooling water temperature. In accordance with the cooling water temperature by seasons, the chillers can maintain highly efficient operation with variable speed control of compressor. Therefore, the chillers are recommended for the customers who need the cooling operation throughout the year.

• COP Characteristics throughout the year

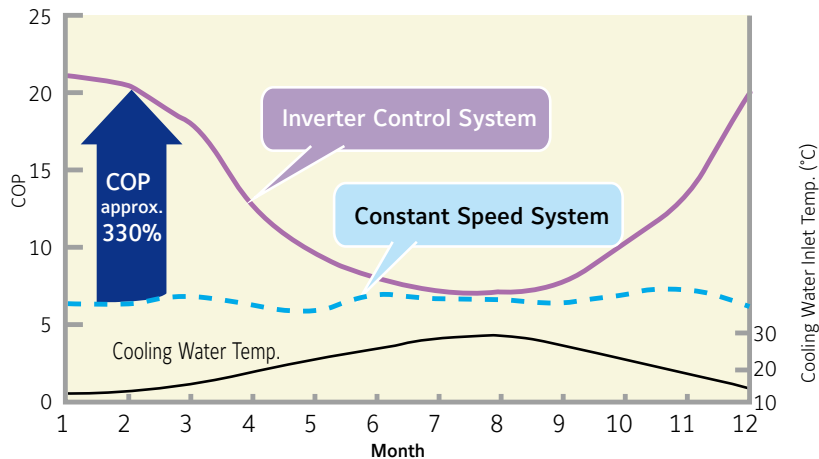



## Excellent COP at Partial Load

Various technologies such as newly developed high efficiency economizer (cyclonic system), etc. enabled drastic improvement of the efficiency at partial load with low cooling water temperature. Improvement of the oil supply temperature control and the automatic oil recovery enables extension of the motor speed control range at low cooling water inlet temperature.

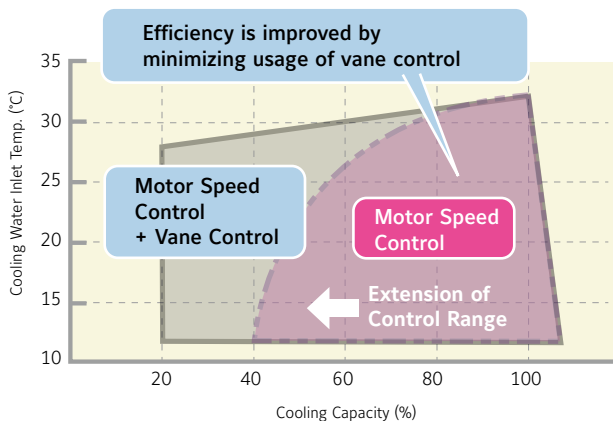
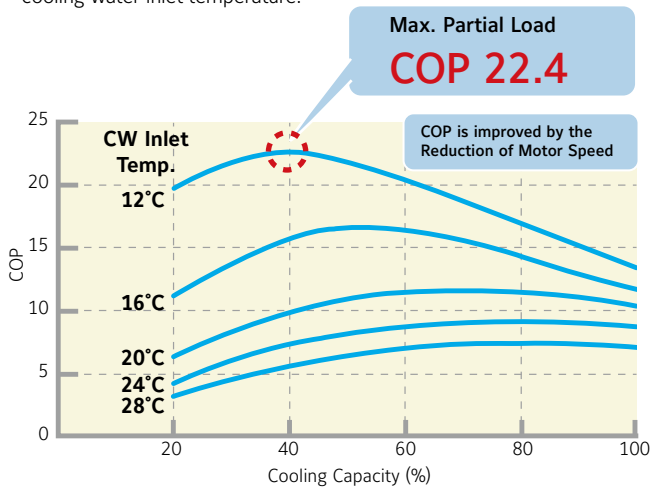

## Improvement of the Oil Supply Temperature Control

When the compressor rotation speed is low, the friction heat generated at bearings decreases. Therefore, refrigerant flow to oil cooler is controlled to keep the oil temperature property.

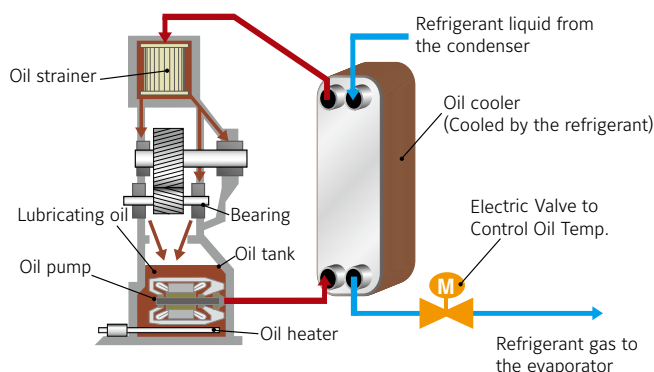

## Energy & Power Saving Operation Functions

### "Eco Mode" Operation (Chilled Water Inlet Temp. Control)

The chiller is usually controlled so the chilled water outlet temperature to be constant. This "Eco Mode" operation introduces the inlet temperature control, where the chilled water inlet temperature is controlled to be constant. The outlet temperature rises a bit but this is enough for the off-peak season air conditioning.

- Comparison of Characteristics between CHW Outlet/Inlet Temp. Control

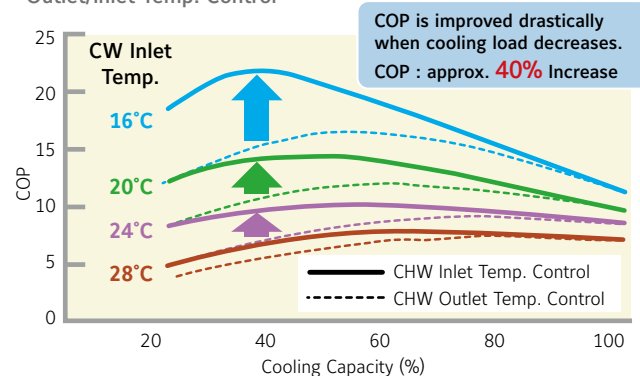

### "Energy Saving Mode" Operation (Peak Cut Operation) (option)

Once the target motor power consumption is set, the chiller is automatically controlled by the motor speed, the inlet guide vane opening and the chilled water outlet temperature rise. This control is extremely useful for the energy saving especially in the off-peak season when the motor speed is easily decreased.

- Energy Saving Mode Setting Screen



### Cooling Water Variable Flow Operation (option)

When the cooling water variable flow control is applied, the cooling water flow rate is automatically calculated so the total power consumption of the compressor motor and the cooling water pump becomes minimum.

- Characteristics of Cooling Water Variable Flow Operation

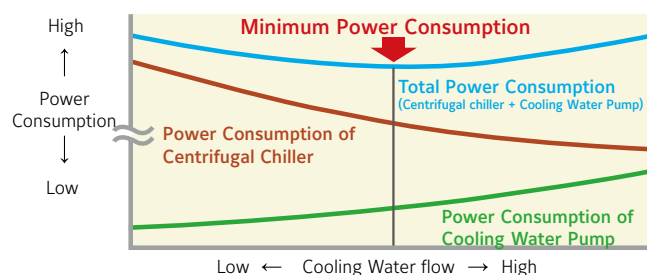

### Harmonic Filter (option)

Harmonic filter is available to comply the requirement of IEEE 519.

# Specifications

## ■ HC-F\_GFG-SSC Constant Speed

Model	Cooling Capacity		Overall Dimension				Shipping Weight kg	Operating Weight kg
	USRT	COP	Length (A) mm	Width (B) mm	Height (C) mm	Extubation Space		
HC-F300GFG-SSC	300 – 325	5.68 – 6.79	4,050	1,650	2,200	3,500	6,100	7,600
HC-F350GFG-SSC	326 – 350	5.69 – 6.80	4,050	1,650	2,200	3,500	6,100	7,000
HC-F400GFG-SSC	351 – 425	5.73 – 6.85	4,550	1,900	2,400	4,000	7,700	9,600
HC-F450GFG-SSC	426 – 450	5.75 – 6.88	4,550	1,900	2,400	4,000	7,700	9,700
HC-F500GFG-SSC	451 – 525	5.82 – 6.96	4,550	2,000	2,500	4,000	9,200	11,100
HC-F550GFG-SSC	526 – 550	5.83 – 6.98	4,550	2,000	2,500	4,000	9,200	11,200
HC-F600GFG-SSC	551 – 625	5.88 – 7.03	4,550	2,000	2,500	4,000	9,400	11,400
HC-F650GFG-SSC	626 – 650	5.92 – 7.08	4,550	2,000	2,500	4,000	9,400	11,600
HC-F700GFG-SSC	651 – 725	5.82 – 6.96	4,550	2,250	2,650	4,000	11,300	13,600
HC-F750GFG-SSC	726 – 750	5.87 – 7.02	4,550	2,250	2,650	4,000	11,300	13,700
HC-F800GFG-SSC	751 – 825	5.92 – 7.08	4,550	2,250	2,650	4,000	11,700	14,400
HC-F850GFG-SSC	826 – 850	5.94 – 7.10	4,550	2,250	2,650	4,000	11,700	14,500
HC-F900GFG-SSC	851 – 925	5.93 – 7.09	4,550	2,400	2,800	4,000	13,100	16,100
HC-F950GFG-SSC	926 – 950	5.92 – 7.08	4,550	2,400	2,800	4,000	13,100	16,200
HC-F1000GFG-SSC	951 – 1,025	5.96 – 7.12	5,050	2,400	2,800	4,500	14,700	18,300
HC-F1050GFG-SSC	1,026 – 1,050	5.96 – 7.12	5,050	2,400	2,800	4,500	14,700	18,400
HC-F1100GFG-SSC	1,051 – 1,100	5.98 – 7.15	5,050	2,400	2,800	4,500	14,800	18,600
HC-F1150GFG-SSC	1,101 – 1,150	6.00 – 7.17	5,050	2,600	2,900	4,500	15,700	19,700
HC-F1200GFG-SSC	1,151 – 1,225	6.03 – 7.21	5,050	2,600	2,900	4,500	16,800	20,800
HC-F1250GFG-SSC	1,226 – 1,275	6.03 – 7.22	5,050	2,600	2,900	4,500	16,800	20,900
HC-F1300GFG-SSC	1,276 – 1,325	6.09 – 7.29	5,050	2,600	2,900	4,500	16,800	21,000
HC-F1350GFG-SSC	1,326 – 1,375	6.09 – 7.28	5,050	2,600	2,900	4,500	17,000	21,300
HC-F1400GFG-SSC	1,376 – 1,400	6.10 – 7.29	5,050	2,600	2,900	4,500	17,000	21,400

## ■ HC-F\_GFG-SITSC Inverter-controlled

Model	Cooling Capacity		Overall Dimension				Shipping Weight kg	Operating Weight kg
	USRT	COP	Length (A) mm	Width (B) mm	Height (C) mm	Extubation Space		
HC-F300GFG-SITSC	300 – 325	5.57 – 6.66	4,050	1,650	2,200	3,500	6,100	7,600
HC-F350GFG-SITSC	326 – 350	5.58 – 6.68	4,050	1,650	2,200	3,500	6,100	7,000
HC-F400GFG-SITSC	351 – 425	5.61 – 6.71	4,550	1,900	2,400	4,000	7,700	9,600
HC-F450GFG-SITSC	426 – 450	5.65 – 6.75	4,550	1,900	2,400	4,000	7,700	9,700
HC-F500GFG-SITSC	451 – 525	5.71 – 6.83	4,550	2,000	2,500	4,000	9,200	11,100
HC-F550GFG-SITSC	526 – 550	5.73 – 6.85	4,550	2,000	2,500	4,000	9,200	11,200
HC-F600GFG-SITSC	551 – 625	5.77 – 6.90	4,550	2,000	2,500	4,000	9,400	11,400
HC-F650GFG-SITSC	626 – 650	5.81 – 6.94	4,550	2,000	2,500	4,000	9,400	11,600
HC-F700GFG-SITSC	651 – 725	5.71 – 6.83	4,550	2,250	2,650	4,000	11,300	13,600
HC-F750GFG-SITSC	726 – 750	5.76 – 6.89	4,550	2,250	2,650	4,000	11,300	13,700
HC-F800GFG-SITSC	751 – 825	5.80 – 6.93	4,550	2,250	2,650	4,000	11,700	14,400
HC-F850GFG-SITSC	826 – 850	5.82 – 6.96	4,550	2,250	2,650	4,000	11,700	14,500
HC-F900GFG-SITSC	851 – 925	5.81 – 6.94	4,550	2,400	2,800	4,000	13,100	16,100
HC-F950GFG-SITSC	926 – 950	5.81 – 6.94	4,550	2,400	2,800	4,000	13,100	16,200
HC-F1000GFG-SITSC	951 – 1,025	5.83 – 6.97	5,050	2,400	2,800	4,500	14,700	18,300
HC-F1050GFG-SITSC	1,026 – 1,050	5.84 – 6.99	5,050	2,400	2,800	4,500	14,700	18,400
HC-F1100GFG-SITSC	1,051 – 1,100	5.86 – 7.01	5,050	2,400	2,800	4,500	14,800	18,600
HC-F1150GFG-SITSC	1,101 – 1,150	5.88 – 7.03	5,050	2,600	2,900	4,500	15,700	19,700
HC-F1200GFG-SITSC	1,151 – 1,225	5.91 – 7.06	5,050	2,600	2,900	4,500	16,800	20,800
HC-F1250GFG-SITSC	1,226 – 1,275	5.92 – 7.07	5,050	2,600	2,900	4,500	16,800	20,900

### REMARKS

- Please consult with our sales staff or distributor for actual specifications for cooling capacity, expected kW input and COP, depending on selected operating parameters.
- The above specifications are subject to change without notice for technical improvements.  
\* This table is applicable to chillers to be manufactured for normal water.
- Capacity control range is 100% to approx. 20%.  
(Minimum cooling capacity can be reduced to 10% as option.)
- Fouling factor is assumed to be 0.018m<sup>2</sup>K/kW for chilled water and 0.044m<sup>2</sup>K/kW for cooling water.
- Standard main power source : 380V/400V/415V/440V/460V (up to HC-F1400GFG-S), 3000V/3300V/6000V/6600V (any capacity, only constant speed), 10000V/11000V (F900GFG-S and above, only constant speed), AC, 50/60Hz, 3ph.
- Auxiliary power: AC 380V/50Hz/3φ/3W or 4W.
- Maximum working pressure is 1.0MPa for both chilled and cooling water.  
If higher maximum working pressure is required, please specify at inquiry.  
(Up to 2.5 MPa is available.)

### ■ Starter Panel (Open star-delta)

Model	Dimensions (mm)			
	Length	Width	Height	
GFG-SSC	300 ~ 450	800	600	2,100
	500 ~ 600	800	750	1,700
	650 ~ 800	1,000	800	1,900
	850 ~ 1000	1,000	800	2,200
	1050 ~ 1400	1,500	1,000	2,100

### ■ Inverter Panel

Model	Dimensions (mm)			
	Length	Width	Height	
GFG-SITSC	300	1,700	950	1,900
	350 ~ 450	1,900	950	1,900
	500 ~ 650	1,900	950	2,300
	700 ~ 850	2,100	950	2,300
	900 ~ 1400	2,200	950	2,450

## ■ HC-F\_GXG-S

### Constant Speed

Model	Cooling Capacity		COP	Overall Dimension mm				Shipping Weight kg	Operating Weight kg
	USRT	kW		Length (A)	Width (B)	Height (C)	Extubation space		
HC-F300GXG-S	300 - 349	1,055 - 1,227	5.15 - 6.16	3,550	1,650	2,200	3,000	5,800	7,000
HC-F350GXG-S	350 - 350	1,231 - 1,231	5.15 - 6.16	3,550	1,650	2,200	3,000	5,800	7,100
HC-F400GXG-S	351 - 449	1,234 - 1,579	5.35 - 6.40	3,550	1,900	2,400	3,000	7,000	8,500
HC-F450GXG-S	450 - 450	1,582 - 1,582	5.36 - 6.41	3,550	1,900	2,400	3,000	7,000	8,600
HC-F500GXG-S	451 - 549	1,586 - 1,930	5.58 - 6.68	4,050	1,900	2,450	3,500	8,400	9,900
HC-F550GXG-S	550 - 599	1,934 - 2,106	5.62 - 6.72	4,050	2,000	2,500	3,500	8,700	10,400
HC-F600GXG-S	600 - 649	2,110 - 2,282	5.70 - 6.82	4,050	2,000	2,500	3,500	8,900	10,500
HC-F650GXG-S	650 - 650	2,285 - 2,285	5.63 - 6.73	4,050	2,000	2,500	3,500	9,100	10,900
HC-F700GXG-S	651 - 749	2,289 - 2,633	5.59 - 6.69	4,050	2,250	2,650	3,500	10,700	12,600
HC-F750GXG-S	750 - 799	2,637 - 2,809	5.65 - 6.75	4,050	2,250	2,650	3,500	10,700	12,700
HC-F800GXG-S	800 - 800	2,813 - 2,813	5.74 - 6.86	4,050	2,250	2,650	3,500	11,100	13,300
HC-F850GXG-S	801 - 899	2,816 - 3,161	5.59 - 6.69	4,050	2,250	2,800	3,500	11,100	13,400
HC-F900GXG-S	900 - 949	3,164 - 3,337	5.65 - 6.75	4,050	2,400	2,800	3,500	12,400	14,800
HC-F950GXG-S	950 - 999	3,340 - 3,512	5.66 - 6.77	4,050	2,400	2,800	3,500	12,400	14,900
HC-F1000GXG-S	1,000 - 1,000	3,516 - 3,516	5.81 - 6.94	4,550	2,400	2,800	4,000	13,900	16,900
HC-F1050GXG-S	1,001 - 1,099	3,520 - 3,864	5.74 - 6.86	4,550	2,400	2,800	4,000	14,100	17,200
HC-F1100GXG-S	1,100 - 1,149	3,868 - 4,040	5.78 - 6.91	4,550	2,400	2,800	4,000	14,300	17,500
HC-F1150GXG-S	1,150 - 1,199	4,043 - 4,216	5.79 - 6.92	4,550	2,600	2,900	4,000	14,800	18,100
HC-F1200GXG-S	1,200 - 1,249	4,219 - 4,391	5.83 - 6.97	4,550	2,600	2,900	4,000	15,800	19,100
HC-F1250GXG-S	1,250 - 1,299	4,395 - 4,567	5.84 - 6.99	4,550	2,600	2,900	4,000	15,800	19,200
HC-F1300GXG-S	1,300 - 1,349	4,571 - 4,743	5.85 - 7.00	4,550	2,600	2,900	4,000	15,800	19,300
HC-F1350GXG-S	1,350 - 1,399	4,747 - 4,919	5.86 - 7.01	4,550	2,600	2,900	4,000	16,000	19,600
HC-F1400GXG-S	1,400 - 1,400	4,922 - 4,922	5.89 - 7.04	4,550	2,600	2,900	4,000	16,000	19,700
HC-F1500GXG-S (*1)	1,401 - 1,599	4,926 - 5,622	5.74 - 6.86	4,850	3,300	3,400	4,000	20,500	24,300
HC-F1600GXG-S (*1)	1,600 - 1,600	5,626 - 5,626	5.77 - 6.90	4,850	3,300	3,400	4,000	20,700	24,600
HC-F1700GXG-S (*1)	1,601 - 1,799	5,629 - 6,325	5.69 - 6.81	5,250	3,500	3,700	4,500	23,700	27,500
HC-F1800GXG-S (*1)	1,800 - 1,899	6,329 - 6,677	5.73 - 6.85	5,250	3,500	3,700	4,500	24,000	27,900
HC-F1900GXG-S (*1)	1,900 - 1,999	6,680 - 7,028	5.77 - 6.90	5,250	3,500	3,700	4,500	24,200	28,200
HC-F2000GXG-S (*1)	2,000 - 2,000	7,032 - 7,032	5.84 - 6.99	5,250	3,500	3,700	4,500	24,500	28,500

\*1. Power source: High/Middle tension Standard starting method: Reactor

## ■ HC-F\_GXG-SIT

### Inverter-controlled

Model	Cooling Capacity		COP	Overall Dimension mm				Shipping Weight kg	Operating Weight kg
	USRT	kW		Length (A)	Width (B)	Height (C)	Extubation space		
HC-F300GXG-SIT	300 - 349	1,055 - 1,227	5.14 - 6.15	3,550	1,650	2,200	3,000	5,800	7,000
HC-F350GXG-SIT	350 - 399	1,231 - 1,403	5.15 - 6.16	3,550	1,650	2,200	3,000	5,800	7,100
HC-F400GXG-SIT	400 - 449	1,407 - 1,579	5.29 - 6.33	3,550	1,900	2,400	3,000	7,000	8,500
HC-F450GXG-SIT	450 - 450	1,582 - 1,582	5.29 - 6.33	3,550	1,900	2,400	3,000	7,000	8,600
HC-F500GXG-SIT	451 - 549	1,758 - 1,930	5.47 - 6.55	4,050	1,900	2,450	3,500	8,400	9,900
HC-F550GXG-SIT	550 - 599	1,934 - 2,106	5.51 - 6.59	4,050	2,000	2,500	3,500	8,700	10,400
HC-F600GXG-SIT	600 - 649	2,110 - 2,282	5.59 - 6.69	4,050	2,000	2,500	3,500	8,900	10,500
HC-F650GXG-SIT	650 - 650	2,286 - 2,286	5.52 - 6.60	4,050	2,000	2,500	3,500	9,100	10,900
HC-F700GXG-SIT	651 - 749	2,461 - 2,634	5.48 - 6.56	4,050	2,250	2,650	3,500	10,700	12,600
HC-F750GXG-SIT	750 - 799	2,637 - 2,810	5.54 - 6.62	4,050	2,250	2,650	3,500	10,700	12,700
HC-F800GXG-SIT	800 - 800	2,813 - 2,813	5.63 - 6.73	4,050	2,250	2,650	3,500	11,100	13,300
HC-F850GXG-SIT	801 - 899	2,989 - 3,161	5.48 - 6.56	4,050	2,250	2,650	3,500	11,100	13,400
HC-F900GXG-SIT	900 - 949	3,165 - 3,337	5.54 - 6.62	4,050	2,400	2,800	3,500	12,400	14,800
HC-F950GXG-SIT	950 - 999	3,340 - 3,513	5.55 - 6.63	4,050	2,400	2,800	3,500	12,400	14,900
HC-F1000GXG-SIT	1,000 - 1,099	3,516 - 3,864	5.69 - 6.81	4,550	2,400	2,800	4,000	13,900	16,900
HC-F1050GXG-SIT	1,001 - 1,099	3,520 - 3,864	5.63 - 6.73	4,550	2,400	2,800	4,000	14,100	17,200
HC-F1100GXG-SIT	1,100 - 1,149	3,868 - 4,040	5.67 - 6.78	4,550	2,600	2,900	4,000	14,300	17,500
HC-F1150GXG-SIT	1,150 - 1,199	4,044 - 4,216	5.67 - 6.78	4,550	2,600	2,900	4,000	14,800	18,100
HC-F1200GXG-SIT	1,200 - 1,249	4,220 - 4,392	5.72 - 6.84	4,550	2,600	2,900	4,000	15,800	19,100
HC-F1250GXG-SIT	1,250 - 1,299	4,395 - 4,568	5.73 - 6.85	4,550	2,600	2,900	4,000	15,800	19,200
HC-F1300GXG-SIT	1,300 - 1,349	4,571 - 4,743	5.73 - 6.85	4,550	2,600	2,900	4,000	15,800	19,300
HC-F1350GXG-SIT	1,350 - 1,350	4,747 - 4,747	5.74 - 6.86	4,550	2,600	2,900	4,000	16,000	19,600

#### REMARKS

- Please consult with our sales staff or distributor for actual specifications for cooling capacity, expected kW input and COP, depending on selected operating parameters.
- The above specifications are subject to change without notice for technical improvements.  
\* This table is applicable to chillers to be manufactured for normal water.
- Capacity control range is 100% to approx. 20%.  
(Minimum cooling capacity can be reduced to 10% as option.)
- Fouling factor is assumed to be 0.018m<sup>2</sup>/K/kW for chilled water and 0.044m<sup>2</sup>/K/kW for cooling water.
- Standard main power source : 380V/400V/415V/440V/460V (up to HC-F1400GXG-S), 3000V/3300V/6000V/6600V (any capacity, only constant speed), 10000V/11000V (F900GXG-S and above, only constant speed), AC, 50/60Hz, 3ph.
- Auxiliary power: AC 380V/50Hz/3φ/3W or 4W.
- Maximum working pressure is 1.0MPa for both chilled and cooling water. If higher maximum working pressure is required, please specify at inquiry. (Up to 2.5 MPa is available.)

#### ■ Starter Panel (Open star-delta)

Model	Dimensions (mm)			
	Length	Width	Height	
GXG-S	300 ~ 450	800	600	2,100
	500 ~ 600	800	750	1,700
	650 ~ 800	1,000	800	1,900
	850 ~ 1000	1,000	800	2,200
	1050 ~ 1400	1,500	1,000	2,100

#### ■ Inverter Panel

Model	Dimensions (mm)			
	Length	Width	Height	
GXG-SIT	300	1,700	950	1,900
	350 ~ 450	1,900	950	1,900
	500 ~ 650	1,900	950	2,300
	700 ~ 850	2,100	950	2,300
	900 ~ 1350	2,200	950	2,450

# Specifications

## ■ HC-F\_GSG-S

### Constant Speed

Model	Cooling Capacity		COP	Overall Dimension (mm)				Shipping Weight (kg)	Operating Weight (kg)
	USRT	kW		Length [A]	Width [B]	Height [C]	Extubation space		
HC-F300GSG-S	300 – 300	1,055-1,055	4.60 – 5.50	2,750	1,900	2,350	2,000	5,500	6,700
HC-F350GSG-S	301 – 350	1,058-1,231	4.66 – 5.58	2,800	2,000	2,350	2,000	6,800	7,500
HC-F400GSG-S	300 – 400	1,055 – 1,406	4.75 – 5.68	2,800	2,000	2,350	2,000	6,900	7,600
HC-F450GSG-S	401 – 450	1,410 – 1,582	4.78 – 5.72	3,250	2,100	2,500	2,500	8,400	9,300
HC-F500GSG-S	451 – 500	1,586 – 1,758	5.02 – 6.01	3,250	2,100	2,500	2,500	8,500	9,400
HC-F550GSG-S	501 – 550	1,762 – 1,934	5.00 – 5.97	3,250	2,100	2,500	2,500	8,600	9,500
HC-F600GSG-S	551 – 600	1,937 – 2,110	5.03 – 6.02	3,250	2,100	2,500	2,500	8,800	9,800
HC-F650GSG-S	601 – 650	2,113 – 2,285	5.07 – 6.06	3,500	2,350	2,700	2,800	10,200	11,600
HC-F700GSG-S	651 – 700	2,289 – 2,461	5.13 – 6.14	3,500	2,350	2,700	2,800	10,300	11,700
HC-F750GSG-S	701 – 750	2,465 – 2,637	5.17 – 6.18	3,500	2,350	2,700	2,800	10,400	11,800
HC-F800GSG-S	751 – 800	2,641 – 2,813	5.34 – 6.38	3,500	2,450	2,800	2,800	11,500	13,000
HC-F850GSG-S	801 – 850	2,816 – 2,989	5.38 – 6.44	3,500	2,450	2,800	2,800	11,600	13,200
HC-F900GSG-S	851 – 900	2,992 – 3,164	5.39 – 6.45	3,750	2,450	2,800	2,800	11,700	13,300
HC-F950GSG-S	901 – 950	3,168 – 3,340	5.19 – 6.20	3,750	2,450	2,800	3,000	12,200	14,200
HC-F1000GSG-S	951 – 1,000	3,344 – 3,516	5.23 – 6.25	3,750	2,450	2,800	3,000	12,300	14,300
HC-F1050GSG-S	1,001 – 1,050	3,520 – 3,692	5.26 – 6.29	3,750	2,450	2,800	3,000	12,400	14,500
HC-F1100GSG-S	1,051 – 1,100	3,695 – 3,868	5.29 – 6.33	3,750	2,650	2,950	3,000	13,200	15,300
HC-F1150GSG-S	1,101 – 1,150	3,871 – 4,043	5.33 – 6.37	3,750	2,650	2,950	3,000	13,300	15,400
HC-F1200GSG-S	1,151 – 1,200	4,047 – 4,219	5.35 – 6.39	3,750	2,650	2,950	3,000	13,400	15,500
HC-F1250GSG-S	1,201 – 1,250	4,223 – 4,395	5.38 – 6.44	3,750	2,650	2,950	3,000	13,500	15,600
HC-F1300GSG-S (*1)	1,251 – 1,300	4,399 – 4,571	5.37 – 6.42	4,700	3,300	3,400	3,500	18,600	21,600
HC-F1350GSG-S (*1)	1,301 – 1,350	4,574 – 4,747	5.38 – 6.44	4,700	3,300	3,400	3,500	18,700	21,700
HC-F1400GSG-S (*1)	1,351 – 1,400	4,750 – 4,922	5.38 – 6.44	4,700	3,300	3,400	3,500	18,800	21,800
HC-F1450GSG-S (*1)	1,401 – 1,450	4,926 – 5,098	5.39 – 6.45	4,700	3,300	3,400	3,500	18,900	22,000
HC-F1500GSG-S (*1)	1,451 – 1,500	5,102 – 5,274	5.40 – 6.46	4,700	3,300	3,400	3,500	19,000	22,100
HC-F1600GSG-S (*1)	1,501 – 1,600	5,278 – 5,626	5.47 – 6.55	5,000	3,500	3,700	4,000	21,000	24,700
HC-F1700GSG-S (*1)	1,601 – 1,700	5,629 – 5,977	5.46 – 6.53	5,000	3,500	3,700	4,000	21,200	25,000
HC-F1800GSG-S (*1)	1,701 – 1,800	5,981 – 6,329	5.39 – 6.45	5,000	3,500	3,700	4,000	21,500	25,400
HC-F1900GSG-S (*1)	1,801 – 1,900	6,332 – 6,680	5.46 – 6.52	5,000	3,500	3,700	4,000	21,700	25,700
HC-F2000GSG-S (*1)	1,901 – 2,000	6,684 – 7,032	5.49 – 6.57	5,000	3,500	3,700	4,000	22,000	26,000

\*1. Power source: High /Middle tension Standard starting method: Reactor

## ■ HC-F\_GSG-SIT

### Inverter-controlled

Model	Cooling Capacity		COP	Overall Dimension (mm)				Shipping Weight (kg)	Operating Weight (kg)
	USRT	kW		Length [A]	Width [B]	Height [C]	Extubation space		
HC-F300GSG-SIT	300 – 300	1,055 – 1,055	4.57 – 5.47	2,800	1,750	2,200	2,000	5,000	6,200
HC-F350GSG-SIT	301 – 350	1,058 – 1,231	4.59 – 5.49	2,900	2,070	2,300	2,000	6,200	6,800
HC-F400GSG-SIT	351 – 400	1,234 – 1,407	4.70 – 5.62	2,900	2,070	2,300	2,000	6,300	7,000
HC-F450GSG-SIT	401 – 450	1,410 – 1,582	4.73 – 5.65	3,190	2,070	2,350	2,500	7,600	8,500
HC-F500GSG-SIT	451 – 500	1,586 – 1,758	4.96 – 5.93	3,190	2,070	2,350	2,500	7,600	8,500
HC-F550GSG-SIT	501 – 550	1,762 – 1,934	4.97 – 5.94	3,190	2,080	2,350	2,500	7,700	8,700
HC-F600GSG-SIT	551 – 600	1,937 – 2,110	4.98 – 5.95	3,190	2,080	2,350	2,500	7,800	8,800
HC-F650GSG-SIT	601 – 650	2,113 – 2,286	5.02 – 6.01	3,490	2,090	2,430	2,800	9,200	10,600
HC-F700GSG-SIT	651 – 700	2,289 – 2,461	5.09 – 6.08	3,490	2,090	2,430	2,800	9,300	10,700
HC-F750GSG-SIT	701 – 750	2,465 – 2,637	5.14 – 6.15	3,490	2,350	2,540	2,800	10,000	11,400
HC-F800GSG-SIT	751 – 800	2,641 – 2,813	5.23 – 6.26	3,490	2,350	2,560	2,800	10,800	12,300
HC-F850GSG-SIT	801 – 850	2,817 – 2,989	5.27 – 6.30	3,490	2,370	2,560	2,800	10,900	12,500
HC-F900GSG-SIT	851 – 900	2,992 – 3,165	5.29 – 6.33	3,490	2,370	2,560	2,800	11,000	12,600
HC-F950GSG-SIT	901 – 950	3,168 – 3,340	5.12 – 6.13	3,740	2,590	2,650	3,000	12,200	14,200
HC-F1000GSG-SIT	951 – 1,000	3,344 – 3,516	5.17 – 6.18	3,740	2,590	2,650	3,000	12,300	14,300
HC-F1050GSG-SIT	1,001 – 1,050	3,520 – 3,692	5.26 – 6.29	3,740	2,590	2,650	3,000	12,400	14,500
HC-F1100GSG-SIT	1,051 – 1,100	3,696 – 3,868	5.23 – 6.26	3,740	2,590	2,710	3,000	13,000	15,100
HC-F1150GSG-SIT	1,101 – 1,150	3,871 – 4,044	5.26 – 6.29	3,740	2,590	2,710	3,000	13,100	15,200
HC-F1200GSG-SIT	1,151 – 1,200	4,047 – 4,220	5.30 – 6.34	3,740	2,590	2,710	3,000	13,200	15,300
HC-F1250GSG-SIT	1,201 – 1,250	4,223 – 4,395	5.33 – 6.37	3,740	2,590	2,710	3,000	13,300	15,400

### REMARKS

- Please consult with our sales staff or distributor for actual specifications for cooling capacity, expected kW input and COP, depending on selected operating parameters.
- The above specifications are subject to change without notice for technical improvements.
  - \* This table is applicable to chillers to be manufactured for normal water.
- Capacity control range is 100% to approx. 20%.  
(Minimum cooling capacity can be reduced to 10% as option.)
- Fouling factor is assumed to be 0.018m<sup>2</sup>/kW for chilled water and 0.044m<sup>2</sup>/kW for cooling water.
- Standard main power source : 380V/400V/415V/440V/460V (up to HC-F1250GSG-S), 3000V/3300V/6000V/6600V (any capacity, only constant speed), 10000V/11000V (F800GSG-S and above, only constant speed), AC, 50/60Hz, 3ph.
- Auxiliary power: AC 380V/50Hz/3φ/3W or 4W.
- Maximum working pressure is 1.0MPa for both chilled and cooling water.  
If higher maximum working pressure is required, please specify at inquiry.  
(Up to 2.5 MPa is available.)

### ■ Starter Panel (Open star-delta)

Model	Dimensions (mm)			
	Length	Width	Height	
GSG-S	300 ~ 400	800	600	2,100
	450 ~ 500	800	750	1,700
	550 ~ 800	1,000	800	1,900
	850 ~ 900	1,000	800	2,200
	950 ~ 1250	1,500	1,000	2,100

### ■ Inverter Panel

Model	Dimensions (mm)			
	Length	Width	Height	
GSG-SIT	300~400	1,900	950	1,900
	450~600	1,900	950	2,300
	650~800	2,100	950	2,300
	850~1250	2,200	950	2,450

# Dimensional Data

## Standard Scope of Supply

The following table shows the standard scope of supply, but the actual scope depends on the contract. Please consult with our sales staff or distributor.

Item	Standard Scope
Main Equipment	Compressor, Main motor, Lubrication system, Heat exchanger
Auxiliary Equipment	Safety device, Control panel, Standard accessories (Corrugated rubber vibration insulator plates, Oil strainer elements, Gasket for oil strainer elements, Dryer), Starter (optional)
Coating	Chiller main unit: Anti-corrosive prime coating Control panel: Finish coat (color: Munsell 5Y8/1 gloss) Starter (optional): Finish coat (color: Munsell 5Y7/1 semigloss)
Out of Supply Scope	Foundation work, Carrying-in, Installation, Piping work, Cold insulation, Primary and secondary side electrical wiring, Commissioning for total system, Forced ventilation system, Outdoor discharge piping for safety valve, Counter flange, Bolt, Nut, Gasket, Foundationbolt, Refrigerant

## Dimensional Outline Drawing

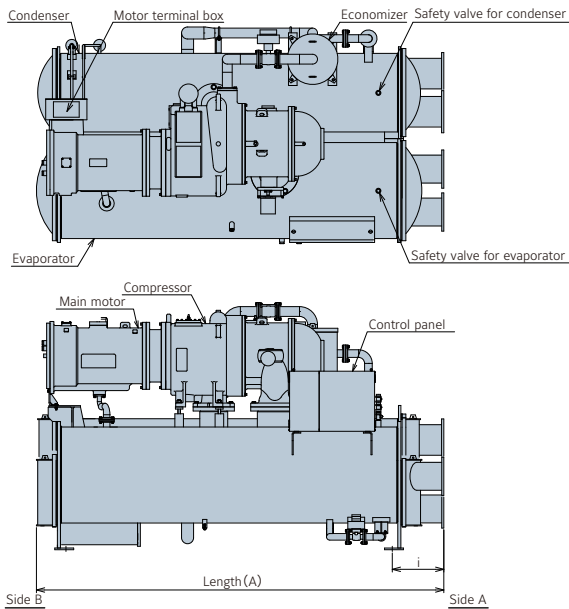

This dimensional outline drawing shows a standard nozzle location. Please consult with our sales staff or distributor in case of a 3-pass or 4-pass system.

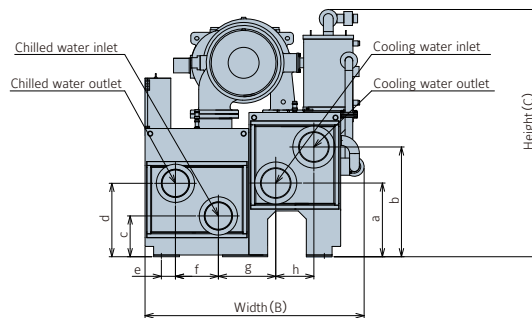

### Positional Dimension of Water Piping

(unit: mm)

Model: HCF_GFG-SSC HCF_GFG-SITSC	Positional dimension of nozzle								
	a	b	c	d	e	f	g	h	i
300, 350	673	933	398	616	33	339	444	290	420
400, 450	715	975	442	642	101	358	525	292	420
500, 550	734	1,027	474	695	102	400	535	320	420
600, 650	734	1,027	494	715	102	400	535	320	420
700 ~ 850	810	1,155	430	730	107	500	562	380	420
900, 950	780	1,160	455	815	139	480	640	380	420
1000, 1050	780	1,160	475	835	139	480	640	380	420
1100	780	1,160	495	855	139	480	640	380	420
1150	858	1,278	456	836	164	500	668	444	420
1200 ~ 1400	858	1,278	456	836	164	500	668	444	420

Model: HCF_GXG-S HCF_GXG-SIT	Positional dimension of nozzle								
	a	b	c	d	e	f	g	h	i
300, 350	673	933	398	616	33	339	444	290	420
400, 450	715	975	442	642	101	358	525	292	420
500	714	974	462	662	101	358	525	292	420
550	734	1,027	474	695	102	400	535	320	420
600, 650	734	1,027	494	715	102	400	535	320	420
700 ~ 850	810	1,155	430	730	107	500	562	380	420
900, 950	780	1,160	455	815	139	480	640	380	420
1000, 1050	780	1,160	475	835	139	480	640	380	420
1100, 1150	858	1,278	456	836	164	500	668	444	420
1200 ~ 1350	858	1,278	475	855	164	500	668	444	420
1400	858	1,278	475	855	164	500	668	444	420
1500	979	1,469	562	1,002	257	600	925	500	612
1600	979	1,469	582	1,022	257	600	925	500	612
1700, 1800	1,005	1,565	603	1,043	269	700	897	580	620
1900, 2000	1,005	1,565	623	1,063	269	700	897	580	620

Model: HCF_GSG-S HCF_GSG-SIT	Positional dimension of nozzle								
	a	b	c	d	e	f	g	h	i
300	673	933	398	616	37	340	444	290	420
350, 400	714	974	422	622	89	358	525	292	420
450	734	1,027	455	676	90	400	535	320	420
500, 550	734	1,027	475	696	90	400	535	320	420
600	734	1,027	495	716	90	400	535	320	420
650, 700	810	1,155	410	710	95	500	562	380	420
750	810	1,155	430	730	95	500	562	380	420
800	800	1,180	436	796	139	480	640	380	420
850, 900	800	1,180	456	816	139	480	640	380	420
950	800	1,180	456	816	139	480	640	380	420
1000, 1050	800	1,180	475	835	139	480	640	380	420
1100, 1150	858	1,278	437	817	164	500	668	444	420
1200, 1250	858	1,278	456	836	164	500	668	444	420
1300 ~ 1400	979	1,469	523	963	257	600	925	500	612
1450, 1500	979	1,469	543	983	257	600	925	500	612
1600, 1700	1,005	1,565	584	1,024	269	700	897	580	620
1800, 1900	1,005	1,565	603	1,043	269	700	897	580	620
2000	1,005	1,565	623	1,063	269	700	897	580	620

# Johnson Controls-Hitachi Air Conditioning

<http://www.jci-hitachi.com>

Distributed By :

--